

TMH SIDE-ENTRY MIXERS



The Plenty TMH Series - Side Entry Mixers, The Plenty Package

Backed by over 60 years operating experience Plenty Mixers, an SPX Brand, has a reference list of successful site installations that is second to none. Plenty Mixers are acknowledged to be the market leader in the field of side entry mixing technology for the oil and petrochemical industries, having supplied literally thousands of units worldwide to numerous major oil companies in over 60 countries around the globe.

Based in Charlotte, North Carolina, SPX Corporation (NYSE: SPW) is a global Fortune 500 multi-industry manufacturing leader with over \$5 billion in annual revenue, operations in more than 35 countries and over 15,000 employees. The company's highly-specialized, engineered products and technologies are concentrated in Flow Technology and energy infrastructure. Many of SPX's innovative solutions are playing a role in helping to meet rising global demand for electricity and processed foods and beverages, particularly in emerging markets. The company's products include food processing systems for the food and beverage industry, power transformers for utility companies, and cooling systems for power plants. For more information, please visit www.spx.com.

Plenty has been supplying fluid agitation equipment for over 60 years and, as an engineering company, has been established for over 200 years providing a wealth of engineering experience. Modern manufacturing techniques produce the highest quality equipment, backed by ISO 9001:2000 accreditation. The Plenty TMH mixers are a durable range of side entry mixers with an extensive application portfolio for blending, storage, or homogeneity duties in diverse industries:

FEATURES:

Plenty TMH Mixers are compact and durable, providing wide process flexibility with assured results.

- High efficiency impellers for optimum mixing and power savings
- Positive shut off device allows mechanical seal and bearing changes under full tank conditions
- Tooth belt for long life and positive engagement between motor and mixer shaft
- All 316 stainless steel wetted parts construction
- Maintenance-free bearings
- Bearing system minimizes seal deflection
- L10 bearing life in excess of 65,000 hours
- Single sleeve mounted mechanical seal
- 4" ANSI mounting flange
- Power range 1.1 - 5.5 kW / 1.5 - 7.5HP
- CE & ATEX 2 G / ATEX 3 G certification available

Belt Drive:

Belt drive, HTD timing belt and PD helical offset belt option

- Large heavy duty ball bearings
- Suitable for 50 and 60 Hz supply
- Fixed output speed 425 RPM +/- 5%

Tank Shut Off:

A taper to taper metal tank shut-off system ensures that the shaft is positively clamped in the shut-off position such that the contents are prevented from escape while the seal is replaced. The system incorporates a safety check valve.

Impellers:

- A312 is standard
- Plenty Forward Rake Propeller is optional



A312



Plenty Forward Rake

Shaft:

A one piece solid shaft accurately machined to specified length and diameter.

Wetted Parts:

The mixers are manufactured as standard with wetted parts in 316 stainless steel.

Other materials can be provided for specific application needs. The wetted parts can also be supplied with a polished finish.

Motor:

- IEC and NEMA are available

Mounting Options:

- 4" ANSI flange is standard

Mechanical Seal:

Mechanical seals are sleeve mounted for ease of maintenance. The mechanical seal is completely enclosed within a seal housing that also incorporates a back up seal to restrict leakage in the event of ultimate seal failure.

An air release valve⁽¹⁾ is fitted to the seal housing for venting the seal chamber to ensure that it is completely filled with product (liquid)

prior to initial and post maintenance start-up. The air release valve is used to prove the shut off is 100% operational before any maintenance work is started.

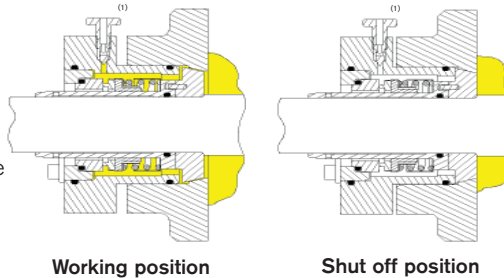

PLENTY TMH SPECIFICATIONS (CERTIFIED DIMENSIONS/WEIGHTS AFTER RECEIPT OF ORDER)					
MOTOR (kW [H.P.])	A (mm [in])	B (mm [in])	C (mm [in])	D (mm [in])	UNIT WEIGHT (kg [lbs])
1.1 [1.5]	150 [5.9]	581 [22.9]	340 [13.4]	104 [4.1]	118 [260]
1.5 [2]	150 [5.9]	581 [22.9]	340 [13.4]	104 [4.1]	119 [263]
2.2 [3]	150 [5.9]	631 [24.8]	358 [14.1]	104 [4.1]	137 [301]
4 [5]	150 [5.9]	631 [24.8]	358 [14.1]	104 [4.1]	140 [308]
5.5 [7.5]	230 [9.1]	754 [29.7]	460 [18.1]	125 [5.9]	165 [363]

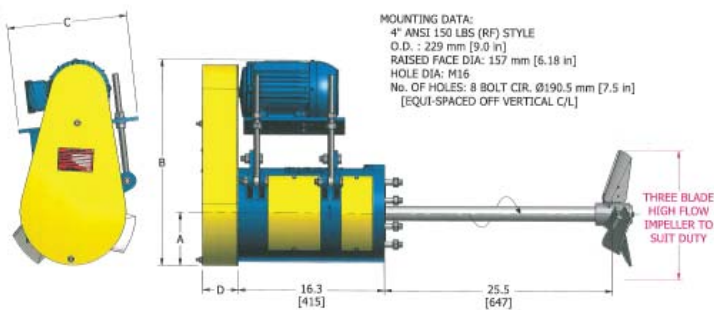

PLENTY TMH PRODUCT SPECIFICATION

					Available A312 Impellers Diameters			
Shaft Dia.	Mounting	Shaft Dia.	Motor kW/HP	Mixer Model Number	14"	16"	18"	20"
38mm	Fixed	Belt	1.1 / 1.5	14A-38-TMH1.5HP	S			
			1.5 / 2	16A-38-TMH2HP	O	S		
			2.2 / 3	16A-38-TMH3HP	O	S		
			4 / 5	18A-38-TMH5HP		O	S	
			5.5 / 7.5	20A-38-TMH7.5HP			O	S

S = Standard, O = Optional

Typical product applications

The Plenty TMH mixers are a durable range of side entry mixers with an extensive application portfolio for blending, storage, or homogeneity duties in diverse industries:

Vegetable Oil Processors



Oil Bunkers and Biofuels Storage



Breweries, Alcohol Distilleries and Wineries



Sugar Refineries



Chemicals



Hydrocarbon Production/ Processing



Soft Drink Manufacturers



Water Treatment





Global locations

AMERICAS

SPX FLOW TECHNOLOGY

Rua João Daprat
231 São Bernardo do Campo
SP 09600-010, Brazil
P: +55 11 2127 8278

SPX FLOW TECHNOLOGY CHILE

SPX Chile Limitada
Av. Ricardo Lyon 222 of. 503
Providencia - Santiago
Chile
P: +56 2 8969 320

SPX FLOW TECHNOLOGY MEXICO

APV Soluciones Integrales, SA de CV
Amargura # 60 Primer Piso
Col. Lomas de La Herradura
52785 Huixquilucan
Edo de Mexico
P: +52 55 5293 9048

EMEA

SPX FLOW TECHNOLOGY

Ocean House, Towers Business Park
Didsbury, Manchester
M20 2LY, UK
P: +44 161 249 1170

SPX FLOW TECHNOLOGY AFRICA

Unit 12B
Growthpoint Office Park, Tonetti Street
Midrand,
South Africa
P: +27 11 207 3700

SPX FLOW TECHNOLOGY MIDDLE EAST FZE

P.O Box 299745,
Downtown Jebel Ali
The Galleries 4
Dubai, U.A.E.
P: +971 4 8143400

APAC

SPX FLOW TECHNOLOGY PTY LTD

Suite 2.3, Quad 2
8 Parkview Drive
Homebush Bay NSW 2127, Australia
P: +61 2 9763 4900

SPX FLOW TECHNOLOGY CHINA

2F, Treasury Centre
No. 1568 Huashan Road
Shanghai 200052, China
P: +86 (21) 22085889

SPX FLOW TECHNOLOGY SINGAPORE

25 International Business Park
03-03/12 German Centre
Singapore 609916
P: +65 6264 4366

SPX FLOW TECHNOLOGY INDIA

Survey No. 275, Odhav Road
Odhav, Ahmedabad - 382415, India
P: +91 79 2287 0311
F: +91 79 2287 0593

SPX FLOW TECHNOLOGY

135 Mt. Read Blvd.
Rochester, NY 14611
P: (888) 649-2378 (MIX-BEST), US and Canada) or +1 (585) 436-5550
F: (585) 436-5589
E: plentymixers@spx.com • <http://www.spx.com/en/plenty/>

For other Sales locations click
<http://www.spx.com/en/lightnin/where-to-buy/>
or use your SmartPhone and the QR Code



SPX reserves the right to incorporate our latest design and material changes without notice or obligation.

Design features, materials of construction and dimensional data, as described in this bulletin, are provided for your information only and should not be relied upon unless confirmed in writing. Please contact your local sales representative for product availability in your region. For more information visit www.spx.com.

The green ">" is a trademark of SPX Corporation, Inc.