

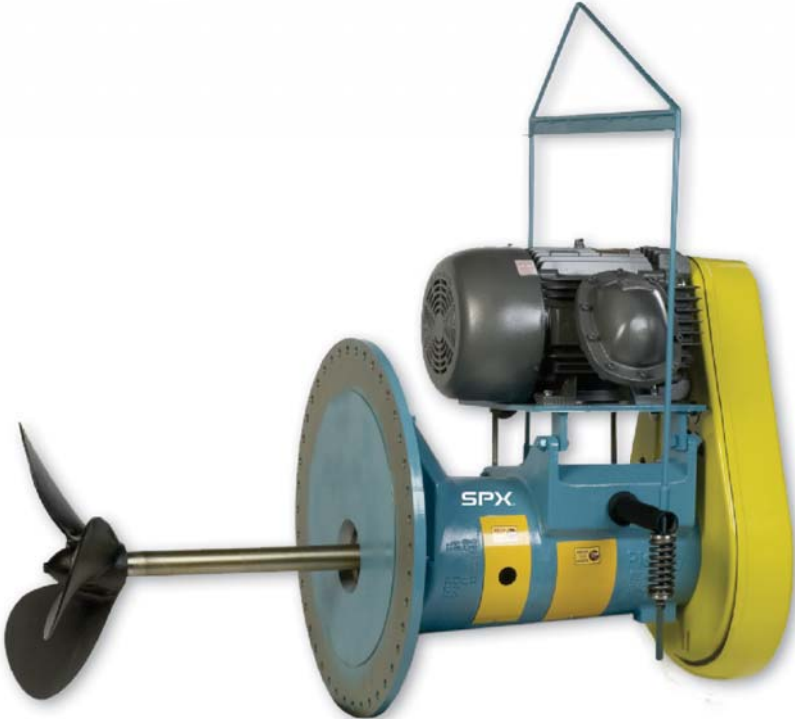

# HEAVY-DUTY SIDE-ENTRY MIXERS



## Plenty Mixers - The Standard for Oil Storage

Backed by over 60 years operating experience Plenty Mixers, an SPX Brand, has a reference list of successful site installations that is second to none. Plenty Mixers are acknowledged to be the market leader in the field of side entry mixing technology for the oil and petrochemical industries, having supplied literally thousands of units worldwide to numerous major oil companies in over 60 countries around the globe.

Based in Charlotte, North Carolina, SPX Corporation (NYSE: SPW) is a global Fortune 500 multi-industry manufacturing leader with over \$5 billion in annual revenue, operations in more than 35 countries and over 15,000 employees. The company's highly-specialized, engineered products and technologies are concentrated in Flow Technology and energy infrastructure. Many of SPX's innovative solutions are playing a role in helping to meet rising global demand for electricity and processed foods and beverages, particularly in emerging markets. The company's products include food processing systems for the food and beverage industry, power transformers for utility companies, and cooling systems for power plants. For more information, please visit [www.spx.com](http://www.spx.com).

Plenty Side Entry Mixers have helped to set the industry international standard. They can outperform other mixers on the market simply by virtue of their technically advanced design, which includes a simple and easily maintainable design, as well as a high efficiency, true helical pitch one piece 'cast' impeller incorporating high blade area and forward rake which was developed by Plenty.



### WHY SIDE ENTRY TANK MIXERS

The Plenty Side Entry mixer is an efficient converter of energy into fluid motion. Unlike jet mixer systems, they do not suffer significant energy losses at the pump, in the pipework, in the bends, or most significantly, at the jet nozzles. Capital costs are low and access to in-tank components is not restricted, while the problem of frequent, urgent maintenance on tanks that must be emptied and cleaned is eliminated. Side Entry mixers are also efficient, and are usually less expensive for larger diameter tanks. Side Entry mixers are ideal for use on tanks with floating roofs where practical considerations preclude the use of top entry mixers.

#### Standard Range:

- 1.5 – 55kW (3 - 75 HP)
- Ø16" to Ø33" impellers
- Belt and Gear Drive
- Fixed and Swivel Angle

These four variables form the comprehensive standard range. In most cases the design concept has been to provide units suitable for long and continuous operation at remote sites with minimum maintenance.



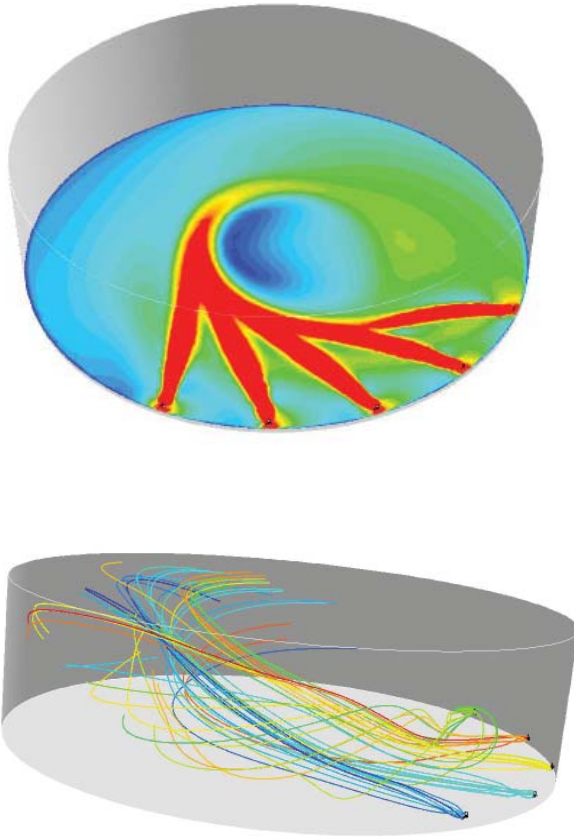

Select SPX Mixing equipment and you get more than an efficient and cost effective process. You get over 85 years of experience in processing technology. We were one of the first to use computational fluid dynamics (CFD). This experience has enabled us to design and develop products specifically for oil storage into the 21st century.

Our laboratory allows us to optimize your process, from pilot to full-scale testing. Your benefits can include higher reliability, lower production costs, greater output, resulting in higher profits.

Processing.....we perfected it.

## Typical product applications

The majority of Side Entry mixers are required to meet one or more of the following duties:

### **Crude Oil BS&W Control**

The main purpose of the mixers in this application is to ensure the developed jet flow is used to lift the BS&W into the body of the crude oil to maintain a relatively clean tank floor. The Swivel Angle mixers used can be varied to direct flow up to 30 degrees either side of the center line of the tank, so that all areas of the tank are swept. It is particularly important to prevent sludge build up or blockage around the tank outlet so the mixer cluster should be situated directly opposite the tank outlet.



### **Blending, maintaining homogeneity and heat transfer**

It is assumed that these duties are with 'clean' product and so Fixed Angle mixers are used. As with Swivel Angle mixers, all should be approx. 22.5 degrees apart and within a 90 degree quadrant.

If it is possible to operate the mixers during 'pump up', up to 50% of process power or time can be saved. To maximize the additive mixer effect of inlet flow and mixer focused



axial flow it is recommended that the mixer cluster be situated approximately 22.5 degrees to the left of the tank inlet. If it is not possible to utilize the 'pump up' time, the position of the mixer group is not critical.

## MECHANICAL SEAL

The mechanical seal was developed in conjunction with a leading manufacturer for use in the Petrochemical field on fluids from asphalt to xylene.

The mechanical seal is completely enclosed inside a housing which is fitted with a close clearance throttle bush outboard of the mechanical seal to restrict leakage rate of tank media in the event of ultimate seal failure.

A safety check valve is fitted for venting the seal chamber to ensure that it is completely filled with liquid prior to start-up as well as to check that the shut-off device is 100% effective.

### Alternate Seal Arrangements:

- Double Mechanical Seal
- Cartridge Seal
- High Temperature Sealing Units
- API/682 Seals

### Leakage Detection Systems

The Plenty seal leakage detection system provides an economical solution to alert the operator of leakage passed the mechanical seal. Any leakage is collected and contained within a collection vessel that is equipped with a level sensor that can activate an alarm in the control room.

## Standard Design Features - Reliability by Design

### IMPELLERS

The high efficiency true helical pitch impeller with forward rake was originally developed by Plenty for Side Entry mixers. Years of research in the field of liquid dynamics have been rewarded by a technically advanced design of impeller, having a large blade area that provides the optimum cavitation-free suction conditions promoting maximum pumping rate and entrainment for any installed power. Each impeller is accurately cast as a one-piece component, thus eliminating the setting variances and welding problems often present with alternative fabricated designs. Rigid inspections of pitch, uniformity and balancing ensure minimal vibration and optimum pumping efficiency.

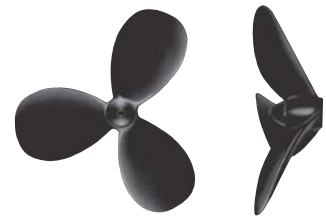

### Advanced Impeller Design:

- High pumping
- High thrust
- Minimum power draw
- Solid one piece design
- No cavitation
- Reliability

### Impeller Fixing

Positive fixing and driving of the impellers on the shaft is achieved by the use of taper to taper shaft connection with side fitting key and retaining bolt.

### BEARINGS

In every case the units are designed and manufactured to require minimum maintenance. The mixer bearings in particular have been engineered to provide long life and to maximize bearing L10 Life.

### TANK MOUNTING MANHOLE - FIXED AND SWIVEL OPTIONS

The most common sizes of tank adaptor flanges to suit ANSI and API standard 24" and 30" are available as standard. Tank adaptor flanges can be supplied to suit all tank manhole/ nozzle fixings. The swivel assembly comprises a stainless steel polished spherical ball attached to the mixer mounting flange and sealed by a Viton Solosele™ which prevents leakage while the mixer is swivelled in a horizontal plane through 60° (30° either side of a line through the mixer centerline). The mixer is supported by robust hinge pins and is provided with a positive clamping arrangement for locking the mixer in positions of 10° intervals.

## GEAR DRIVEN MIXER

Driven by a vertical electric motor which is flange mounted on the support bracket above the gearbox and connected by an all metal flexible coupling protected by a guard. The gearbox comprises a single reduction hardened high efficiency spiral bevel gear set having a minimum service factor of 1.5 to AGMA Standards. The gears and all bearings are splash oil lubricated and enclosed in a large gear case for maximum heat dissipation. The mixer frame is a rigid one-piece iron casting spigot located on the gearbox and the steel mounting flange.

## BELT DRIVEN MIXER

A horizontal foot mounted motor is fitted above the main mixer frame on a steel mounting plate which allows adjustment for correct belt tensioning. Motor mounting plate hinges and belt adjustment screws are corrosion protected against atmospheric corrosion. The motor and mixer shafts are connected by a Fire Resistant Anti-Static (FRAS) High Torque Drive (parallel or chevron) Tooth Belt correctly sized to transmit motor power. The pulleys have taper lock bushes for ease of removal and are enclosed in a spark proof and weatherproof guard. Drive service factor is 1.5 minimum.

The main mixer frame is a rigid one-piece casting spigot located to the steel mounting flange which incorporate pre-lubricated, sealed for life, and hermetically sealed shaft bearings. The mounting flange incorporates a single mechanical seal with a corrosion and wear resistant tank shut-off device permitting seal and bearing replacement under full tank conditions.

## SHAFTS

The shaft has been designed to minimize misalignment, deflection and vibration which all affect the mechanical seal and bearing life. It is a one-piece component with no intermediate couplings and is ground between centers at the bearing and seal areas. All shafts are hard-chrome plated in seal and shut-off areas. The range of Plenty mixers has been designed for heavy-duty operation and the large diameter shafts have a first critical speed of at least 250% of the operating speed. The shaft is supported by heavy duty antifriction bearings, outboard of tank product, making maintenance easier and allowing the performance to be monitored.

## LEGISLATION REQUIREMENTS

SPX manufactures Plenty Mixers so that they are suitable for installation in coastal environments all over the world. As such regional legislative needs are met as standard, these include:

- CE
- ATEX (up to Category 2G IIc gases)
- OSHA
- GOST

## UNIQUE TANK SHUT-OFF DEVICE

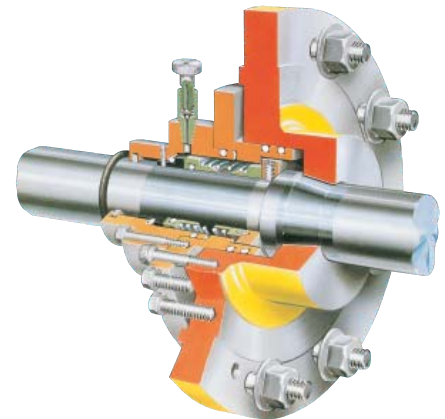

All units incorporate a tank shut-off device to allow the shaft seal and bearings to be changed under full tank conditions. The tank shut-off mechanism incorporates tapered metal to metal faces, positively clamped by a bolted flange which both seals products in the tank and securely supports the shaft during bearing and/or shaft seal changes. All tapered faces are wear and corrosion resistant. The most important aspect of the Plenty Shut-off and mechanical seal assembly is that it incorporates a safety check valve for ensuring that the shut-off is 100% effective before removal of any bearings or the mechanical seal. The Plenty shut-off mechanism offers complete safety and security as it does not incorporate any flexible 'O' rings or gaskets which deform, wear, or perish.



55kW Swivel Gear Mixers installed with Automatic Actuator

## THE ADVANTAGES OF OPERATING PLENTY SWIVEL ANGLE MIXERS IN CRUDE OIL STORAGE TANKS

In most crude oils there are varying quantities of Bottom Sludge and Water (BS&W) which contains paraffins, heavy ends, sediments of sand / silts and water. The rate of accumulation varies with the quality of the crude stored.

### Some of the main reasons why BS&W should be controlled are:

- Tankage is always available for storage and not out of commission being cleaned or repaired
- Problems of sludge disposal are overcome.
- No environmental problems.
- Accumulation of BS&W can cause severe corrosion of tank floor and lower shell plates.
- Hazardous, dangerous and costly tank cleaning is practically eliminated.
- Large accumulations of BS&W can dramatically reduce 'operations' flexibility.
- Up to 70% of the BS&W is recoverable hydrocarbons which result in lost revenue if not utilized.
- Large accumulations, if not controlled or monitored, can result in floating roof damage when tank is on pump-down condition.
- If slugs of BS&W break free during pump-down then serious damage to the transfer pumps or even disruption of the refinery operation can result.
- Elimination of "plugged" water drains.

## Crude Oil, Bottom Sludge and Water (BS&W)

Swivel Angle mixers incorporate a feature which allows the mixer angle of entry to be varied through 30° either side of the tank centerline in 10° increments and enables the entire tank floor to be directly scoured by the impeller flow stream. This is the only satisfactory solution to BS&W control in large tanks and ensures that the heavy solids, water and corrosive salts which settle in areas least agitated by a permanently fixed mixer are maintained in suspension.

The mixer module is supported by two swivel hinge bearings which ensure ease of manual angle changing and the swivel seal is affected by a heavy duty static Soloseal™ acting on a stainless steel spherical ball.

As an alternative to this manual facility, an automatic swivel actuator can be supplied as an optional extra.

The Automatic Swivel Actuator is a shaft belt driven or an electric motor driven speed reducer and linkage, which allows the mixer to swivel 30 degrees in either direction.

Using the shaft driven actuator provides constant motion of the swivel while the mixer is in operation. This option removes the need for expensive additional field wiring.

With the electric motor driven actuator the timer controller provided will cycle on even 24 hours and swivel the mixer 10 degrees each time. This allows for efficient cleaning of the tank bottom and eliminates the need for routine manual adjustment.



Plenty Automatic Actuator



Plenty Mechanical Actuator

## Swivel Angle Mixers Mixer Positioning:

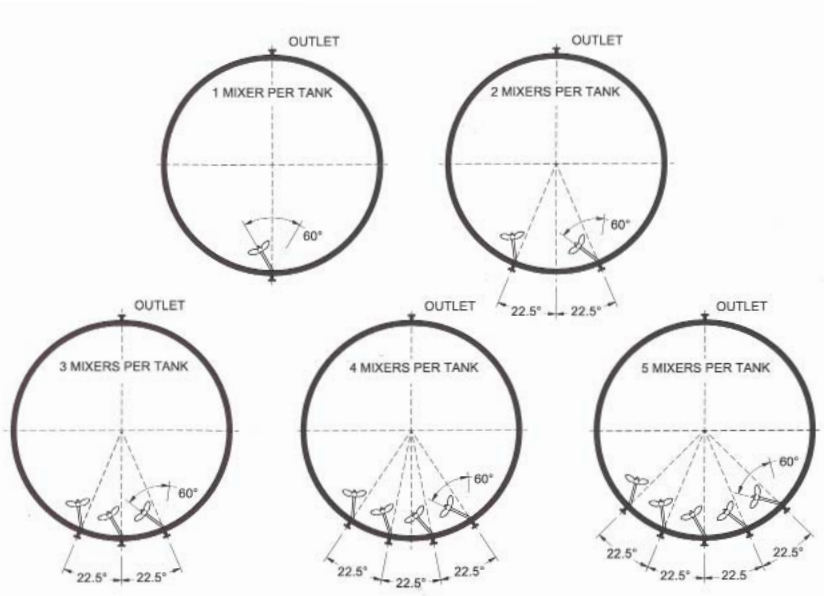

Plenty recommended mixer (Swivel Angle) positions for effective B.S. & W. control in crude oil tanks

### CRUDE OIL BS&W CONTROL

To control or prevent the accumulation of bottom sludge and water pockets (BS&W) especially in Crude Oil Storage Tanks at Refineries, Terminals or Entreports demands high velocity circulation in order to completely scour the bottom of the tank.



### OPERATION: SWIVEL ANGLE MIXERS

Normally used for suspension of sludge, solids etc., with occasionally a further requirement for blending (mixer set in 10° left position). For optimum mixing efficiency the mixers should be operated on the following swivel program.

### CLEAN OR NEW TANKS - SOLIDS SUSPENSION

30° left, 10° right, 20° left, 20° right, 10° left, 30° right, 30° left etc., angle changes being made every 2-3 months maximum. Specific process guidance is available from SPX.

### DIRTY TANKS - SOLIDS SUSPENSION

Program as for clean tanks but initially the mixer should operate for approximately 8 hours on one angle per batch i.e., first batch 30° left, second batch 10° right, and so on until such time that the deposits are reduced to a reasonable level. Then revert to a change of swivel angle every 2-3 months. Specific process guidance is available from SPX.

### BLENDING, MAINTAINING HOMOGENEITY, TEMPERATURE, UNIFORMITY

The mixer should be positioned at the 10° left angle to ensure full top to bottom turnover.

## Fixed Angle Mixers Mixer Positioning:

### MAINTAINING HOMOGENEITY

To maintain homogeneity of refinery finished or intermediate products or chemical plant feed stocks to ensure uniform specification. This demands complete movement throughout the tank with top to bottom "turnover" as well as circulation round the tank, to ensure that the product at the top, middle and bottom remains uniform to specification.

### BLENDING

To mix two or more different components to obtain a homogeneous blend in a specified time to specific requirements again demands complete top to bottom "turnover".

### TEMPERATURE UNIFORMITY

To aid heat transfer while heating or cooling or to maintain temperature uniformity - again complete fluid motion, top to bottom "turnover" would normally be required. Location of mixers relative to the heating element is also important to the success of the operation.

### COMBINED DUTIES

It is possible that one or more of the duties may apply to a particular application and the most critical duty must determine the selection of mixer. Generally the most power demanding duty is blending.

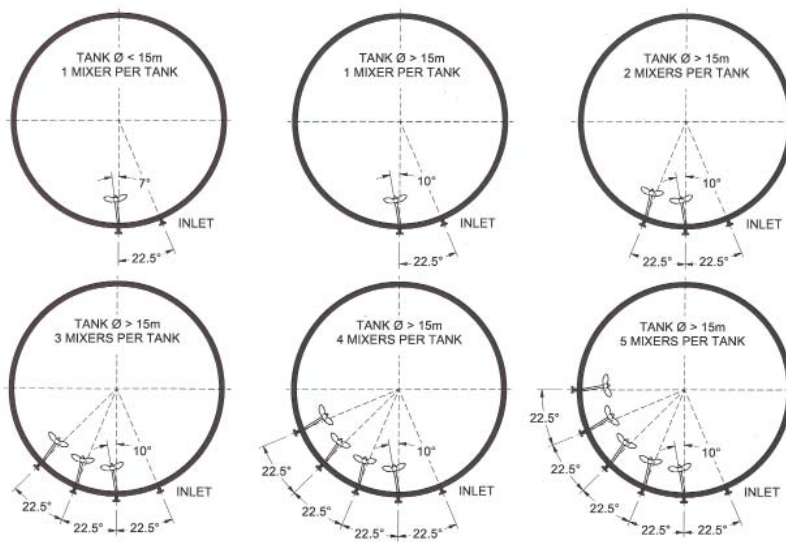

Plenty recommended mixer (Fixed Angle) positions for effective blending, homogeneity and temperature uniformity

### HOMOGENEITY

Side Entry mixers induce a spiral focused axial flow across the floor of the tank continually entraining product from other areas of the tank. This jet stream initially only agitates the higher gravity product in the bottom of the tank, but in time, providing there is the necessary installed power, will gradually penetrate the higher layers of the tank product with sufficient velocity to generate both full top to bottom flow and to break the interface between the various densities and achieve a full homogeneous mix. If the actual height/diameter (Z/T) ratio is excessive this will influence the total power required. For each application there is a minimum power below which no matter how long the mixer is operated a blend or homogeneity will never be achieved. For product storage tanks this figure is generally 1.1kW per 1000m<sup>3</sup> (0.25HP per 1000 bbls).

### BLENDING

It will be appreciated that to blend the tank contents in 12 hours would require approximately half the power required to do the same duty in 6 hours and approximately twice as much power as would be necessary in 24 hours. It is, however, necessary to appreciate that some time is required to get the tank contents in motion before the necessary flow pattern is established to enable the mixing process to commence. As already discussed there is a minimum power required for a given volume below which the necessary fluid motion would never be developed for minimal process requirements.



# Manway Dimensions

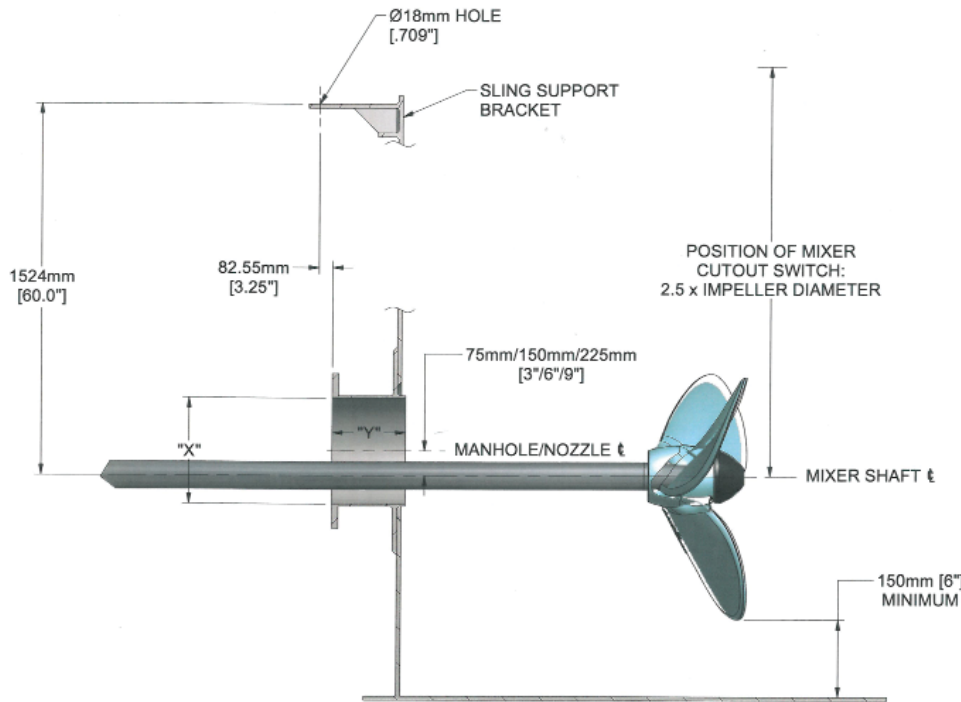

Manway Dimensions are available to the following standards:

18", 20", 24", 30" ANSI and API Drilling patterns. Manways are supplied to Plenty Standard Thickness or full thickness to ANSI or API Codes.

Consult the relevant code for dimensions.

Alternative sizes and custom manways are available.

| MANHOLE OR NOZZLE SIZE | BORE "X" (MM) | NOZZLE LENGTH "Y" (INCHES)         |    |    |    |    |    |    |        |        |        |
|------------------------|---------------|------------------------------------|----|----|----|----|----|----|--------|--------|--------|
|                        |               | 6                                  | 7  | 8  | 9  | 10 | 11 | 12 | 12 3/4 | 13 3/4 | 14 3/4 |
|                        |               | MAXIMUM IMPELLER DIAMETER (INCHES) |    |    |    |    |    |    |        |        |        |
| 18" ANSI 150           | 16.93         | 22                                 | 20 | 20 | 18 | 18 | 18 | 18 | 18     | 18     | 18     |
| 20" ANSI 150           | 18.9          | 26                                 | 24 | 22 | 20 | 20 | 20 | 20 | 20     | 20     | 20     |
| 20" API 650            | 20            | 28                                 | 24 | 24 | 24 | 22 | 22 | 22 | 22     | 22     | 20     |
| 24" ANSI 150           | 22.84         | 32                                 | 32 | 31 | 31 | 28 | 26 | 26 | 26     | 26     | 24     |
| 24" API 650            | 24            | 33                                 | 33 | 32 | 32 | 29 | 28 | 28 | 32     | 26     | 26     |
| 30" ANSI 150           | 28.35         | 33                                 | 33 | 33 | 33 | 33 | 32 | 32 | 32     | 32     | 32     |
| 30" API 650            | 30            | 33                                 | 33 | 33 | 33 | 33 | 33 | 33 | 33     | 33     | 33     |

| MANHOLE OR NOZZLE SIZE | BORE "X" (MM) | NOZZLE LENGTH "Y" (MM)         |     |     |     |     |     |     |     |     |     |
|------------------------|---------------|--------------------------------|-----|-----|-----|-----|-----|-----|-----|-----|-----|
|                        |               | 150                            | 175 | 200 | 225 | 250 | 275 | 300 | 325 | 350 | 375 |
|                        |               | MAXIMUM IMPELLER DIAMETER (MM) |     |     |     |     |     |     |     |     |     |
| 18" ANSI 150           | 430           | 560                            | 510 | 510 | 460 | 460 | 460 | 460 | 460 | 460 | 460 |
| 20" ANSI 150           | 480           | 660                            | 610 | 560 | 510 | 510 | 510 | 510 | 510 | 510 | 510 |
| 20" API 650            | 508           | 700                            | 610 | 610 | 610 | 560 | 560 | 560 | 560 | 560 | 510 |
| 24" ANSI 150           | 580           | 815                            | 815 | 790 | 790 | 700 | 660 | 660 | 660 | 660 | 610 |
| 24" API 650            | 610           | 840                            | 840 | 815 | 815 | 740 | 700 | 700 | 660 | 660 | 660 |
| 30" ANSI 150           | 720           | 840                            | 840 | 840 | 840 | 840 | 815 | 815 | 815 | 815 | 815 |
| 30" API 650            | 762           | 840                            | 840 | 840 | 840 | 840 | 840 | 840 | 840 | 840 | 840 |

# Homogeneity & Blending Mixers - Fixed Angle Mixer Dimensions

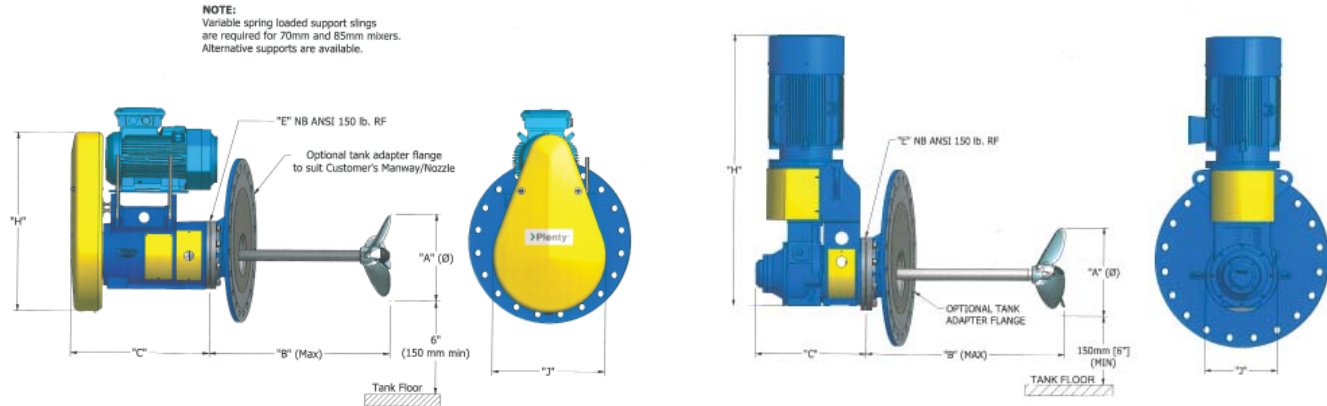

## BELT MIXERS

| Shaft DIA: AT SEAL   |          | 45 mm                                      | 60 mm                                  | 70 mm                                   | 85 mm                                   |
|----------------------|----------|--|--|---|---|
| Drive / *Nominal RPM |          | 431  | 440                                    | 406                                     | 409                                     |
| <b>A (Diameter)</b>  |          | <b>To Suit Specific Process Conditions</b> |  |   |   |
| <b>B</b>             | mm / in. | 705 / 27 <sup>3</sup> / <sub>4</sub> "     | 860 / 33 <sup>3</sup> / <sub>4</sub> " | 1105 / 43 <sup>1</sup> / <sub>2</sub> " | 1180 / 46 <sup>1</sup> / <sub>2</sub> " |
| <b>C</b>             | mm / in. | 560 / 22"                                  | 680 / 26 <sup>3</sup> / <sub>4</sub> " | 860 / 34"                               | 960 / 37 <sup>3</sup> / <sub>4</sub> "  |
| <b>E (Bore)</b>      | mm / in. | 203 / 8"                                   | 203 / 8"                               | 254 / 10"                               | 254 / 10"                               |
| <b>H</b>             | mm / in. | 600 / 23 <sup>3</sup> / <sub>4</sub> "     | 910 / 36"                              | 1100 / 45 <sup>3</sup> / <sub>4</sub> " | 1245 / 49"                              |
| <b>J</b>             | mm / in. | 380 / 15"                                  | 575 / 22 <sup>3</sup> / <sub>4</sub> " | 725 / 28 <sup>1</sup> / <sub>2</sub> "  | 725 / 28 <sup>1</sup> / <sub>2</sub> "  |

\* Based on 60Hz motors

Dimensions are approximate only and certified drawings will be supplied at time of order.

## GEAR MIXERS

| Shaft DIA: AT SEAL   |          | 60 mm                                      | 85 mm                                   |
|----------------------|----------|--|---|
| Drive / *Nominal RPM |          | 425  | 420                                     |
| <b>A (Diameter)</b>  |          | <b>To Suit Specific Process Conditions</b> |   |
| <b>B</b>             | mm / in. | 875 / 34 <sup>1</sup> / <sub>2</sub> "     | 1185 / 46 <sup>3</sup> / <sub>4</sub> " |
| <b>C</b>             | mm / in. | 515 / 20 <sup>1</sup> / <sub>4</sub> "     | 695 / 27 <sup>1</sup> / <sub>4</sub> "  |
| <b>E (Bore)</b>      | mm / in. | 203 / 8"                                   | 254 / 10"                               |
| <b>H</b>             | mm / in. | 1076 / 42 <sup>1</sup> / <sub>2</sub> "    | 1475 58"                                |
| <b>J</b>             | mm / in. | 340 / 13 <sup>1</sup> / <sub>2</sub> "     | 425 / 16 <sup>3</sup> / <sub>4</sub> "  |

\* Based on 60Hz motors

Dimensions are approximate only and certified drawings will be supplied at time of order.

# Crude Oil Storage, BS&W Mixers - Swivel Angle Mixer Dimensions

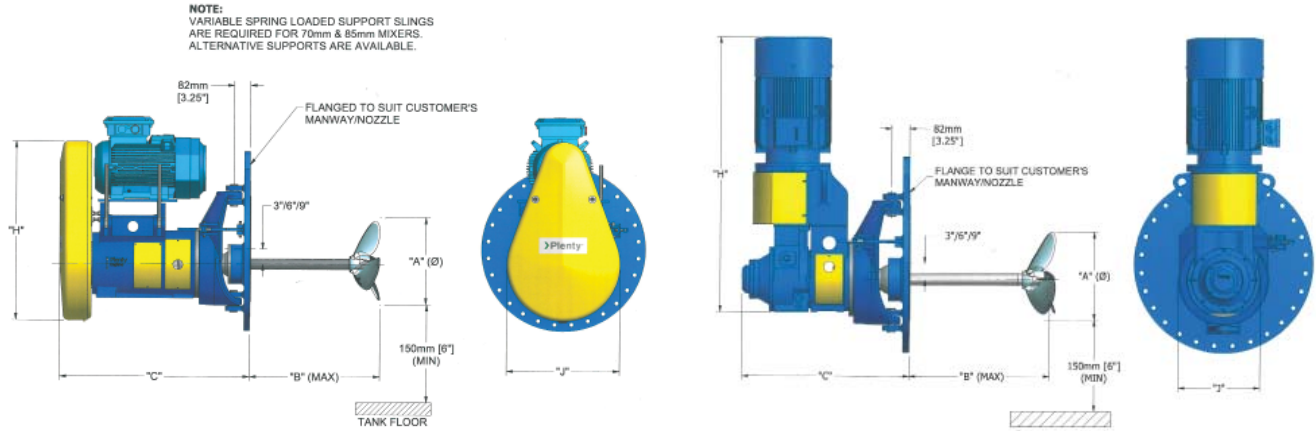

## BELT MIXERS

| Shaft DIA: AT SEAL   |          | 60 mm                                      | 70 mm                                   | 85 mm                                   |
|----------------------|----------|--|---|---|
| Drive / *Nominal RPM |          | 440  | 406                                     | 409                                     |
| <b>A (Diameter)</b>  |          | <b>To Suit Specific Process Conditions</b> |   |   |
| <b>B</b>             | mm / in. | 705 / 27 <sup>3</sup> / <sub>4</sub> "     | 850 / 33 <sup>1</sup> / <sub>2</sub> "  | 925 / 36 <sup>1</sup> / <sub>2</sub> "  |
| <b>C</b>             | mm / in. | 935 / 37"                                  | 1110 / 43 <sup>3</sup> / <sub>4</sub> " | 1210 / 47 <sup>1</sup> / <sub>2</sub> " |
| <b>H</b>             | mm / in. | 910 / 36"                                  | 1160 / 45 <sup>3</sup> / <sub>4</sub> " | 1245 / 49"                              |
| <b>J</b>             | mm / in. | 575 / 22 <sup>3</sup> / <sub>4</sub> "     | 725 / 28 <sup>1</sup> / <sub>2</sub> "  | 725 / 28 <sup>1</sup> / <sub>2</sub> "  |

\* Based on 60Hz motors

Dimensions are approximate only and certified drawings will be supplied at time of order.

## GEAR MIXERS

| Shaft DIA: AT SEAL   |          | 60 mm                                      | 85 mm                                  |
|----------------------|----------|--|--|
| Drive / *Nominal RPM |          | 425  | 420                                    |
| <b>A (Diameter)</b>  |          | <b>To Suit Specific Process Conditions</b> |  |
| <b>B</b>             | mm / in. | 720 / 28 <sup>1</sup> / <sub>4</sub> "     | 930 / 36 <sup>1</sup> / <sub>2</sub> " |
| <b>C</b>             | mm / in. | 770 / 30 <sup>1</sup> / <sub>2</sub> "     | 995 / 39 <sup>1</sup> / <sub>4</sub> " |
| <b>H</b>             | mm / in. | 1076 / 42 <sup>1</sup> / <sub>2</sub> "    | 1475 / 58"                             |
| <b>J</b>             | mm / in. | 340 / 13 <sup>1</sup> / <sub>2</sub> "     | 425 / 16 <sup>3</sup> / <sub>4</sub> " |

\* Based on 60Hz motors

Dimensions are approximate only and certified drawings will be supplied at time of order.

# HEAVY-DUTY SIDE-ENTRY MIXERS



## Global locations

### AMERICAS

#### SPX FLOW TECHNOLOGY

Rua João Daprat  
231 São Bernardo do Campo  
SP 09600-010, Brazil  
P: +55 11 2127 8278

#### SPX FLOW TECHNOLOGY CHILE

SPX Chile Limitada  
Av. Ricardo Lyon 222 of. 503  
Providencia - Santiago  
Chile  
P: +56 2 8969 320

#### SPX FLOW TECHNOLOGY MEXICO

APV Soluciones Integrales, SA de CV  
Amargura # 60 Primer Piso  
Col. Lomas de La Herradura  
52785 Huixquilucan  
Edo de Mexico  
P: +52 55 5293 9048

### EMEA

#### SPX FLOW TECHNOLOGY

Ocean House, Towers Business Park  
Didsbury, Manchester  
M20 2LY, UK  
P: +44 161 249 1170

#### SPX FLOW TECHNOLOGY AFRICA

Unit 12B  
Growthpoint Office Park, Tonetti Street  
Midrand,  
South Africa  
P: +27 11 207 3700

#### SPX FLOW TECHNOLOGY MIDDLE EAST FZE

P.O Box 299745,  
Downtown Jebel Ali  
The Galleries 4  
Dubai, U.A.E.  
P: +971 4 8143400

### APAC

#### SPX FLOW TECHNOLOGY PTY LTD

Suite 2.3, Quad 2  
8 Parkview Drive  
Homebush Bay NSW 2127, Australia  
P: +61 2 9763 4900

#### SPX FLOW TECHNOLOGY CHINA

2F, Treasury Centre  
No. 1568 Huashan Road  
Shanghai 200052, China  
P: +86 (21) 22085889

#### SPX FLOW TECHNOLOGY SINGAPORE

25 International Business Park  
03-03/12 German Centre  
Singapore 609916  
P: +65 6264 4366

#### SPX FLOW TECHNOLOGY INDIA

Survey No. 275, Odhav Road  
Odhav, Ahmedabad - 382415, India  
P: +91 79 2287 0311  
F: +91 79 2287 0593

#### SPX FLOW TECHNOLOGY

135 Mt. Read Blvd.  
Rochester, NY 14611  
P: (888) 649-2378 (MIX-BEST), US and Canada) or +1 (585) 436-5550  
F: (585) 436-5589  
E: plentymixers@spx.com • <http://www.spx.com/en/plenty/>

For other Sales locations click  
<http://www.spx.com/en/lightnin/where-to-buy/>  
or use your SmartPhone and the QR Code



SPX reserves the right to incorporate our latest design and material changes without notice or obligation.

Design features, materials of construction and dimensional data, as described in this bulletin, are provided for your information only and should not be relied upon unless confirmed in writing. Please contact your local sales representative for product availability in your region. For more information visit [www.spx.com](http://www.spx.com).

The green ">" is a trademark of SPX Corporation, Inc.

ISSUED 12/2012 PLM-104

COPYRIGHT © 2012 SPX Corporation